



Air Curtain Owner's Manual

Models:

TFD | TSD | EHD | BPA | XPA



IMPORTANT!

- 1. CHECK FOR DAMAGE:** When you receive your air curtain, immediately check for visible or concealed damage. Claims should be made immediately to the transportation company. Powered Aire will not be liable for damage claims submitted late.
- 2. LOCATE AND RETAIN THE SERIAL NUMBER:** The unit's serial number is necessary to request technical support, order replacement parts or to acquire a wiring diagram. The serial number is located on a silver sticker located on the right side end cap when facing the front of the air curtain.

**For PARTS, TECHNICAL SUPPORT or INFORMATION
call: 1-888-321-2473**



Trained and experienced mechanic/electrician required for installation.

Powered Aire will not be responsible for misplaced switches.

Please review the following instructions for unpacking your air curtain and preparing it for installation.

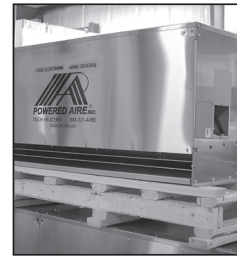

- 1. Remove shrink-wrap and wood slats from top and sides of crate.**

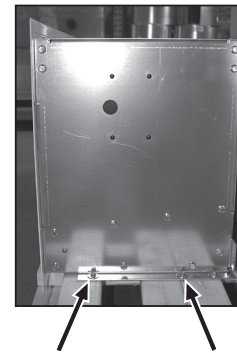

- 2. The air curtain has rear flanges with six holes for ½ inch bolts which are used to lag the unit to the bottom of the crate frame. Unscrew to remove air curtain. For convenience, these same holes can be used if mounting the air curtain directly to the wall.**

Location of Remote Switches

If remote switches are supplied with the air curtain they are shipped inside the Control Panel enclosure.



Electrical Installation:

Units must be field wired in accordance with all local and national electric codes, including wire size and materials.

INSTALLATION OPTIONS

Models TFD, TSD, EHD and BPA
(Contact Factory for Model XPA)

Electrical Installation:

Units must be field wired in accordance with all applicable local, state, provincial and national laws, including wire size and materials.

Mounting Note:

The air curtain should be mounted as close to the door header/opening as possible for maximum performance. For every one inch the bottom of the air curtain is mounted above the door header, the back side of air curtain should be moved away from the wall ½ inch.

Mounting Option 1:

Top Mount - Unit has four 1 1/2 inch holes (TFD 1 5/2 inch) for installing one end of 1/2" (TFD 3/16 inch) threaded rods. The other ends of the threaded rods can be attached to the ceiling. Washers and lock washers or locknuts are recommended. Mounting structure should be of sufficient strength to hold air curtain, and hardware (supplied by others) should be of sufficient strength and quality to support the unit safely. Additional mounting holes are provided on larger units for buildings where structural support is not adequate for supporting the air curtain from ends only.

Mounting Option 2:

Wall Mount - Rear flanges of air curtain have six holes, for six 1/2 inch bolts or lags with washers. When wall mounting use all six holes.

NOTE: Order air curtain wide enough to clear door track system. If not, brackets may be used in conjunction with threaded rod to install the unit.

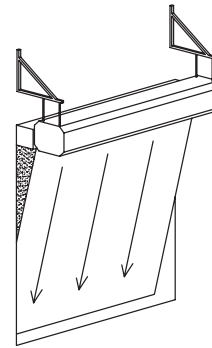
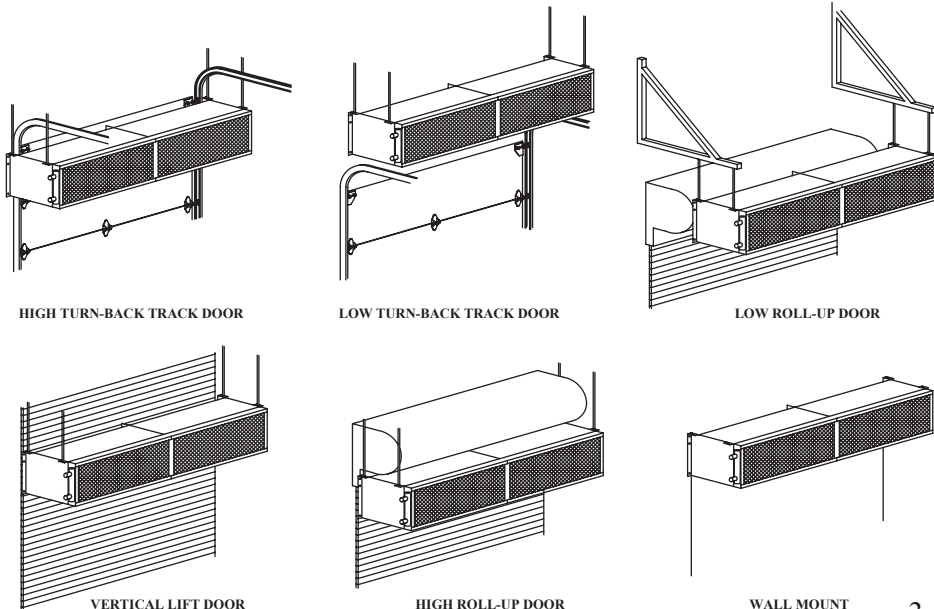

WHEN TO USE SIDE BAFFLES

At times it is necessary to install an air curtain in front of an obstruction such as a door canister. Moving the air curtain away from the wall will create triangular gaps on both sides of the opening where outside air may enter. For maximum effectiveness gaps can be sealed off with a permanent barrier or PVC strips to prevent air from entering. See drawing at right.

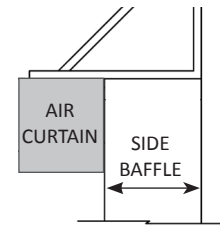

NOTE:
It is recommended that the baffle extends to the floor.

Replacement Parts Model: TFD

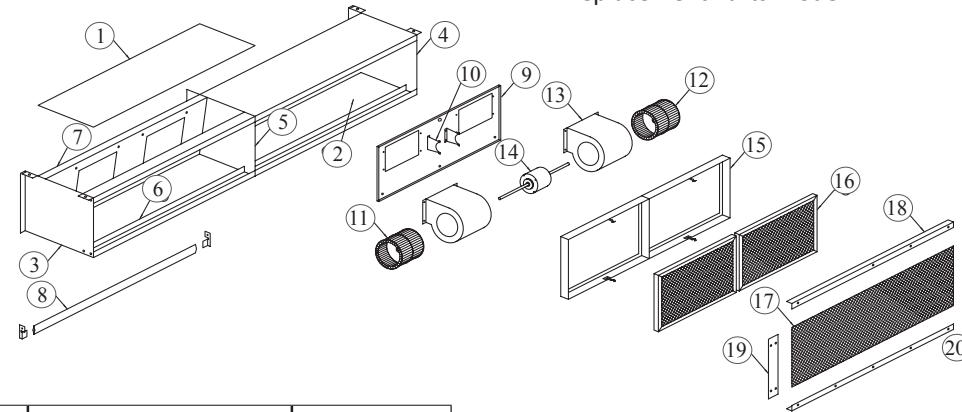

ITEM	DESCRIPTION	PART#
1	36" TOP PANEL	TFD-36-TOP-PNL
1	48" TOP PANEL	TFD-48-TOP-PNL
1	60" TOP PANEL	TFD-60-TOP-PNL
2	36" BOTTOM PANEL	CMCL-36-TBPL
2	48" BOTTOM PANEL	CMCL-48-TBPL
2	60" BOTTOM PANEL	CMCL-60-TBPL
3	LEFT SIDE PANEL	TFD-SDPL-L
4	RIGHT SIDE PANEL	TFD-SDPL-R
5	INTERIOR SIDE PANEL	TFD-ISPL
6	36" STRUT	CMCL-36-STRT
6	48" STRUT	CMCL-48-STRT
6	60" STRUT	CMCL-60-STRT
7	36" PLENUM	TFD-36-PLSA
7	48" PLENUM	TFD-48-PLSA
7	60" PLENUM	TFD-60-PLSA
8	36" STEERING VANE ASSEMBLY	TFD-36-SVA
8	48" STEERING VANE ASSEMBLY	TFD-48-SVA
8	60" STEERING VANE ASSEMBLY	TFD-60-SVA
9	MOTOR / BLOWER PLATE	CMCL-MTPL
10	MOTOR MOUNT	2120-051A-TFD
11	BLOWER WHEEL (LEFT)	TFDBLR-WH-L
12	BLOWER WHEEL (RIGHT)	TFDBLR-WH-R

ITEM	DESCRIPTION	PART#
13	BLOWER HOUSING	TFDBLR-HS
14	MOTOR (120/208-230 VOLT, SINGLE PHASE)	F56AB19C26P
14	MOTOR (480 VOLT, SINGLE PHASE)	F56AB17C26P
14	MOTOR (575 VOLT, SINGLE PHASE)	F56AB18C26P
14	MOTOR (208-230/460 VOLT, THREE PHASE)	P56AF64C26P
14	MOTOR (575 VOLT, THREE PHASE)	P56AF62C26P
15	18" FILTER FRAME	CMCL-FLT-18
15	24" FILTER FRAME	CMCL-FLT-24
15	30" FILTER FRAME	CMCL-FLT-30
16	18" FILTER	CMCL-FLT-18
16	24" FILTER	CMCL-FLT-24
16	30" FILTER	CMCL-FLT-30
17	36" INTAKE SCREEN	CMCL-36-SCRN
17	48" INTAKE SCREEN	CMCL-48-SCRN
17	60" INTAKE SCREEN	CMCL-60-SCRN
18	36" TOP/BOTTOM SCREEN SUPPORT	CMCL-36-TBSB
18	48" TOP/BOTTOM SCREEN SUPPORT	CMCL-48-TBSB
18	60" TOP/BOTTOM SCREEN SUPPORT	CMCL-60-TBSB
19	CENTER SCREEN SUPPORT	CMCL-SOCS
20	SIDE SCREEN SUPPORT	CMCL-SSBR

INSTALLATION NOTE

The bottom of the air curtain should be flush with the top of the opening if possible. If not and the air curtain has to be raised, the following applies: **For every one inch the bottom of the air curtain is mounted above the door header, the back side of the air curtain should be moved away from the wall ¼ inch.**

INCORRECT Installation

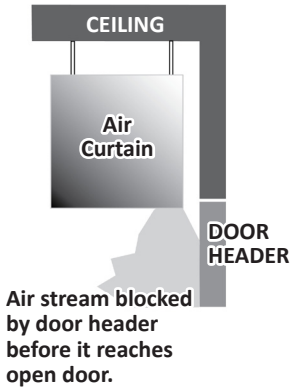

CORRECT Installation

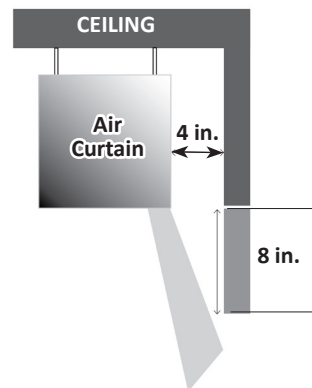

RETURN POLICY

- For all warranty issues contact factory at 724-588-3305 (toll-free: 1-888-321-2473).
- All returns must be approved in advance and accompanied by an RGA number or will not be accepted.
- Once units have been installed no returns will be allowed.
- Units that are returned damaged will not be accepted and full payment will be required.
- No returns will be allowed after 10 working days from shipment.
- Contact factory for Restocking Fee Schedule.

TROUBLESHOOTING

* REPAIRS SHOULD BE PERFORMED BY A MECHANIC / ELECTRICIAN

SYMPTOMS	POSSIBLE CAUSES	CHECK/REMEDIES
NON-OPERATIONAL	Main circuit breaker or disconnect is in OFF position.	Move switch to ON position or reset.
	Loose electrical connection.	Check / tighten connection.
	Fuse blown.	Replace fuse.
MINIMAL / NO AIR	Intake screen and filter clogged.	Remove, clean and / or replace.
	Air intake restricted.	Remove obstruction or move air curtain.
	Fan not rotating.	Affix set screw(s) to shaft.
	Air discharge inadequate.	Obstruction in discharge path (i.e. door headers, automatic door openers, etc.) Move air curtain.
	Air discharge deflecting into wall.	For every 1 inch air curtain is mounted above the door header, air curtain should be moved away from the wall ¼ inch.
	Negative air pressure.	Equalize building pressure.
	Multiple motor units: (only) one motor not operating.	Repair or replace motor.
EXCESSIVE BLOWER NOISE/ VIBRATION	Blower wheel loose on motor shaft.	Tighten set screw(s).
	Air intake vibration.	Tighten air intake screws.
	Blower wheel dirty.	Remove and clean.
	Damaged blower or unbalanced wheel.	Repair or replace.
	Motor being worn.	Replace motor.
	Fan hitting / rubbing fan housing.	Motor shaft bent. Repair or replace. Free housing from fan's path.
EXCESSIVE AIR SPILL TO OUTSIDE OR INSIDE	Nozzle angle too great.	Optimum angle setting is 15 degrees towards outside.

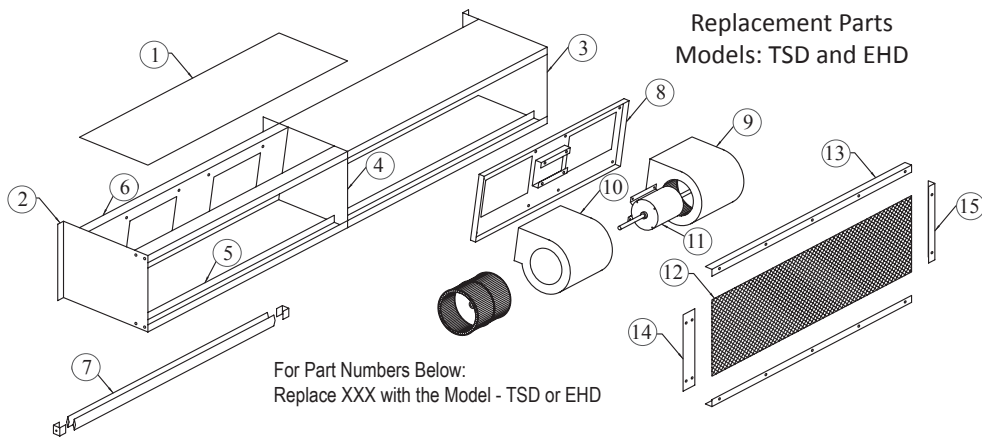

ITEM	DESCRIPTION	PART#	ITEM	DESCRIPTION	PART#
1	48" TOP / BOTTOM PANEL	2148-051	8	MOTOR / BLOWER PLATE	2148-056
1	60" TOP / BOTTOM PANEL	2152-051	9	RIGHT BLOWER WITH HOUSING	XXXBLWR-R
1	72" TOP / BOTTOM PANEL	2167-051	10	LEFT BLOWER WITH HOUSING	XXXBLWR-L
2	LEFT SIDE PANEL	2148-052L	11	MOTOR, 3 H.P. (208-230/480V) TSD	37G561-3-480
3	RIGHT SIDE PANEL	2148-052R	11	MOTOR, 3 H.P. (575V) TSD	37G561-3-575
4	INTERIOR SIDE PANEL	2148-057	11	MOTOR, 5 H.P. (208-230/480V) EHD	EHD-MTR-480
5	48" STRUT	2148-055	11	MOTOR, 5 H.P. (575V) EHD	EHD-MTR-575
5	60" STRUT	2152-055	12	48" INTAKE SCREEN	2148-061
5	72" STRUT	2167-055	12	60" INTAKE SCREEN	2152-061
6	48" PLENUM	2148-011	12	72" INTAKE SCREEN	2167-061
6	60" PLENUM	2152-011	13	48" TOP/BOTTOM SCREEN SUPPORT	2148-064
6	72" PLENUM	2167-011	13	60" TOP/BOTTOM SCREEN SUPPORT	2152-064
7	48" STEERING VANE ASSEMBLY	SVA-48	13	72" TOP/BOTTOM SCREEN SUPPORT	2167-064
7	60" STEERING VANE ASSEMBLY	SVA-60	14	CENTER SCREEN SUPPORT	2148-063
7	72" STEERING VANE ASSEMBLY	SVA-72	15	SIDE SCREEN SUPPORT	2148-062

MAINTENANCE

*Before any internal maintenance is performed be sure all power to unit is disconnected and locked out.

NOTE: Convenient Access Panels

Industrial models are equipped with access panels for inspection, cleaning or removal of motor blower assembly. This way, Individual motor and fan assembly can be removed without lowering the unit or lowering the bottom half of the unit.

- Periodically clean return air intake screen (or re-cleanable filter if supplied in place of a screen). The interval in between cleaning will vary per location depending on the amount of particles in the air. The holes in the screen must be free from obstructions to ensure that the blowers can get enough air to function properly. (If supplied with a filter in place of an intake screen, remove filter, then flush with hot water or steam. Filters are made of rustproof aluminum or galvanized steel. After cleaning, allow the filter to dry before returning it to the unit).
- For units with hot water or steam coil, while cleaning screens and/or filters, visually inspect the heat exchanger fins to ensure they are not clogged up or damaged.
- While doing routine maintenance, verify that the discharge steering vanes are adjusted properly. The steering vanes come pre-set from the factory and will not need adjusted in most cases. In some cases of extreme conditions such as that of high winds, the steering vanes can be adjusted to point further towards the outside to counteract the wind.

To adjust steering vanes, loosen screws on each side of the steering vane assembly. Rotate steering vane assembly to desired location and re-tighten screws.



- Periodically do a visual inspection on the unit to ensure that the unit is not damaged and is operating properly with all motors spinning.
- Industrial units with (except for the TFD) will need to have the motors greased annually under normal operating conditions. Under extreme operating conditions the motors will need greased more frequently, ranging between monthly and quarterly depending on the severity of the ambient environment. There are two grease fittings per motor.

*Note that the air curtain blowers are direct drive so there are no belts to maintain.

LIMITED WARRANTY

Scope of Warranty: Powered Aire's products are warranted against defects in Powered Aire workmanship and materials. Powered Aire Inc. and its employees are committed to providing our customers with the best designed and manufactured Air Curtains / Door Heaters. We welcome comments and questions regarding our products. Please contact us at Powered Aire Inc. Phone: 724-588-3305.

Warranty Period: Powered Aire unheated air curtains are warranted for 60 months from the date of shipment. All other Powered Aire heated air curtains are warranted for 24 months from the date of shipment. All warranty claims must be submitted to Powered Aire prior to the expiration date of the warranty period. All warranties cover parts only. If Powered Aire does not supply the controls for the air curtain, the unit will not be warranted.

Procedure to Receive Warranty Service: Customer should take or ship prepaid the Powered Aire product requiring warranty service to Powered Aire. Contact the Home Office for authorization number. Include an explanation of the defect or problem, a description of the way in which the Powered Aire product is used, and your name, telephone number and address. Tag shipment with authorization number. **Repair by Other than Powered Aire:** Customers who are unable to take or ship the Powered Aire product to the factory, should contact the home office. A repair by anyone other than Powered Aire authorized personnel must be approved in advance by Powered Aire. **Repairs Outside the Scope of Warranty:** Problems with Powered Aire products can be due to improper maintenance, faulty installation, non Powered Aire additions or modifications, or other problems not due to defects in Powered Aire workmanship or materials. If the authorized Powered Aire Service Company determines that the problem with a Powered Aire product is not due to defects in Powered Aire workmanship or materials, then the customer will be responsible for the cost of any necessary repairs. Customers not satisfied with a determination that a problem is outside of warranty coverage should contact the Powered Aire Home Office. **Repairs or Replacement Within the Scope of the Warranty:** If a Powered Aire product is defective due to Powered Aire workmanship or materials and the defect occurs during the warranty period, then Powered Aire will either repair the product or replace it with a new one, whichever Powered Aire believes to be appropriate under the circumstances. Powered Aire is not responsible for the removal and shipping of the Powered Aire product to the home office, the reinstallation of Powered Aire product upon its return to the customer, or any incidental or consequential damages resulting from the defect, removal, reinstallation, shipment or otherwise.

Intended Use: Powered Aire products are designed for industrial / commercial applications.

Product Specifications: All product specifications, applications and other information provided in Powered Aire's catalog and publications are subject to correction and change without notice and should be confirmed by the Home Office. **Extended Warranties:** Extended warranties are available. They will be negotiated individually. Extended warranties are subject to the terms and procedures of this Limited Warranty and Service Policy as modified by the additional terms of the extended warranty. **No Other Warranties and Liability Limitation:** This Limited Warranty represents Powered Aire's sole and exclusive warranty obligation with respect to Powered Aire products. Powered Aire's liability to customer or any other person shall not exceed the Powered Aire's sales price of the applicable Powered Aire Product. Powered Aire disclaims all other expenses and implied warranties including the implied warranties of fitness for a particular purpose and merchantability.

109 Mortensen Rd., Greenville, PA 16125

Phone: 724-588-3305 Toll-Free: 1-888-321-2473

www.poweredaire.com