



MP-HW



MP-ST

MP-HW/ST



The MP HW/ST offers the same features and functions as all MP units (compact size, easy-to-install, low profile) but is available with Hot Water and Steam fittings to connect with buildings using hot water or steam as the primary source of heat. The MP HW/ST meets all the necessary criteria to be used as an exception to vestibules (ANSI/AMCA 220 Standard) in new construction and retrofit applications for offices, restaurants, hospitals, grocery stores and other applications where a vestibule can be eliminated.

OPTIONS

HEATING

Unheatedpg 131
Electric.....pg 133

FILTER

½" Cleanable (Unheated only)

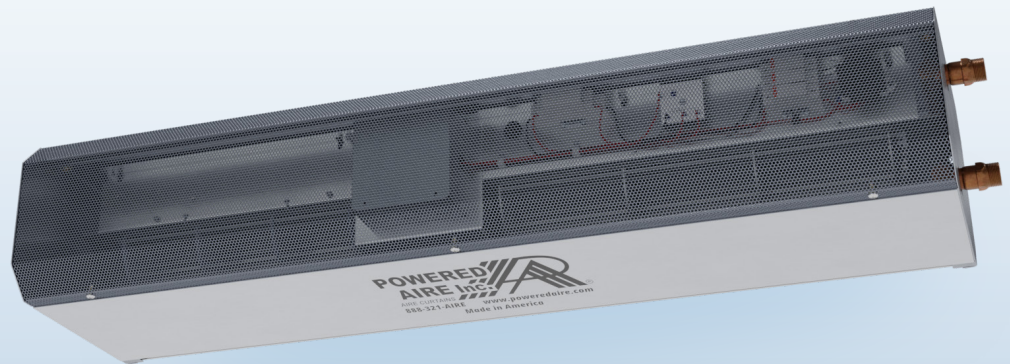

AT A GLANCE

Single Incremental Widths

30" to 10'

Max Installation Height

10'

Heavy Duty Motors

1/5 HP

KEY DESIGN FEATURES

- Meets current ASHRAE 90.1 and IECC requirements for vestibule exception
- Hot Water unit adapts to buildings using Hot Water as primary means of heating
- 18-gauge 304 stainless steel in a number three finish (for brushed stainless steel units only)
- Designed for compact spaces such as the area above drive-thru windows or restaurant doors
- Can be used as an exception to vestibules

RECOMMENDED CONTROLS

- Magnetic Door Switch for activation
- Built-in Time Delay Relay

