

▶ ETA & ETA-E | MECHANICAL DETAILS & DRAWINGS

ETA & ETA-E | Mechanical Information Table

MODEL	Overall Width (in.)	Nozzle Width (in.)	Mounting Width (in.)
ETA-1-36 (E)	37	36	36.06
ETA-1-42 (E)	43	42	42.06
ETA-1-48 (E)	49	48	48.06
ETA-1-60 (E)	61	60	60.06
ETA-2-72 (E)	73	72	72.06
ETA-2-84 (E)	85	84	84.06
ETA-2-96 (E)	97	96	96.06
ETA-3-108 (E)	109	108	108.06
ETA-3-120 (E)	119	118	118.06
ETA-3-132 (E)	134	133	133.06
ETA-4-144 (E)	146	145	145.06
ETA-4-156 (E)	158	157	157.06
ETA-4-168 (E)	170	169	169.06

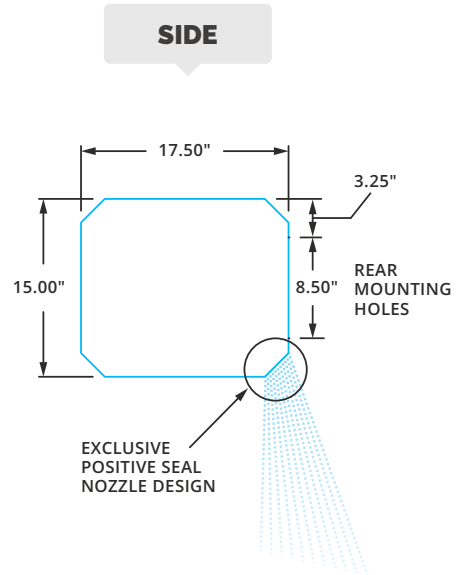

TOP

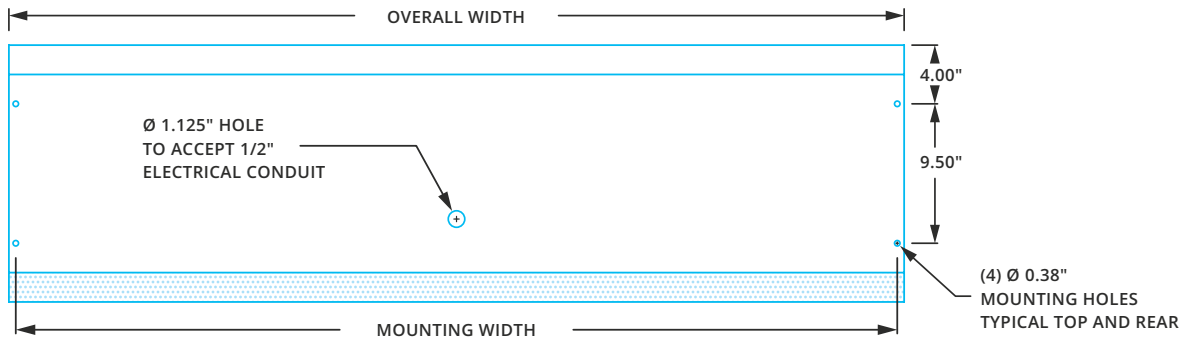

FRONT



BOTTOM

