

▶ HDX | MECHANICAL DETAILS & DRAWINGS

HDX | Mechanical Information Table

MODEL	Overall Width (in.)	Nozzle Width (in.)	Mounting Width Rear (in.)	Mounting Width Top (in.)
HDX-1-60	63	60	61.5	59
HDX-1-72	75	72	73.5	71
HDX-2-120	123.12	120.12	121.62	119.12
HDX-2-132	135.12	132.12	133.62	131.12
HDX-2-144	147.12	144.12	145.62	143.12
HDX-3-180	183.24	180.24	181.74	179.24
HDX-3-192	195.24	192.24	193.74	191.24

SIDE

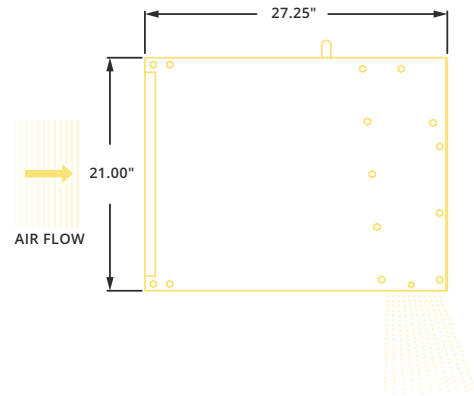

TOP

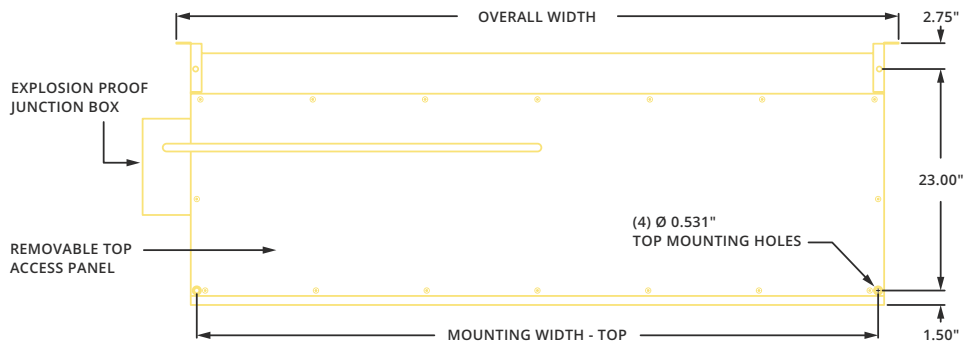

FRONT

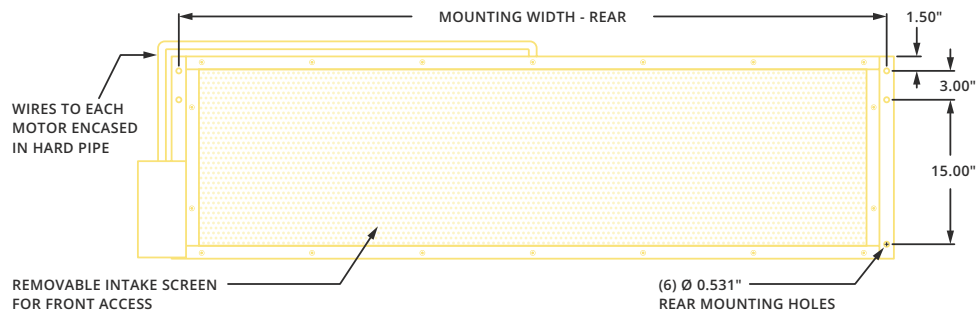

BOTTOM

