



TDG



The TDG is a direct-gas fired, heated air curtain used for climate control and to stop cold drafts from entering door openings in industrial settings including dock doors, loading docks and other delivery doors. The TDG pulls air across the flame of the direct gas heater, blanketing the full length and width of the door with warm air. The effective climate control gained by the TDG results from a discharge temperature of 105° F, even if the entering air temperature is 0° F. The TDG provides a maximum temperature rise of 105° F. This unit is commonly used where temperature is critical to maintain. It also boosts employee comfort and productivity around doors where excessive cold air can make work more difficult.

NOTE

Direct Gas Fired Air Curtain must be ducted to the outside for 100% fresh air.

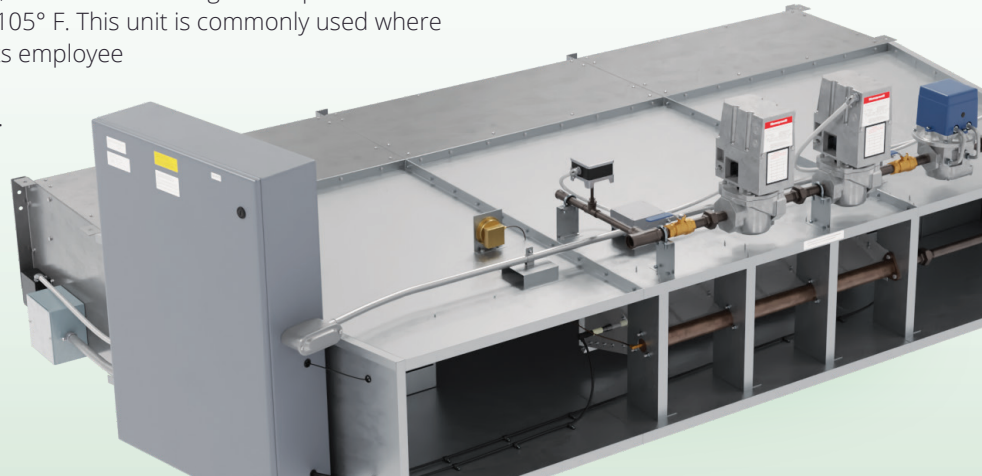

AT A GLANCE

Single Incremental Widths

6' to 12'

Max Installation Height

12'

Heavy Duty Motors

3/4 HP

KEY DESIGN FEATURES

- All weight bearing structural support is 14-gauge stainless steel. Case equipped with stainless steel access panels for inspection, cleaning or removal of motor blower assembly.
- Heavy duty 3/4 HP motors. 1630 rpm each.
- Direct gas heater equipped with a temperature sensor that controls the heater output by way of modulating gas valve. An airflow switch along with a motor contactor will ensure that the burner will not fire without the fans spinning. In case of flame failure, the flame safety relay energizes the alarm lockout relay shutting down the entire system. The system will only restart if the flame safety relay is manually reset.
- Units equipped with proof of closure on the main gas valve, as well as high and low gas pressure switches.
- Direct gas fired panels are mounted to the unit and contain a 24-volt control transformer, flame safety relay, temperature sensor, air flow sensor and modulating gas valve controls.
- Top and bottom access panels to replace or service motors or blowers without lowering entire unit or bottom half of unit. The motor/blower plate comes out as an entire piece.
- Control panel included

RECOMMENDED CONTROLS

- HAND / OFF / AUTO switch
- Magnetic Door Switch for activation
- Built-in time delay relay
- Thermostat

